

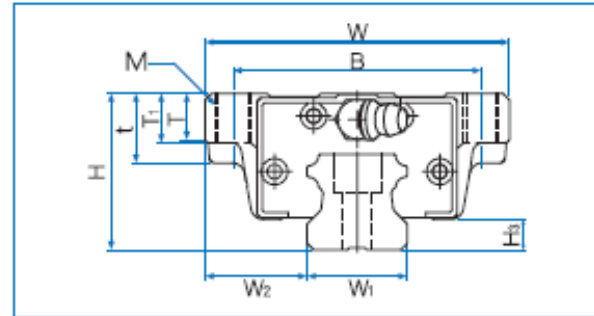

HEXELUS

H-F Series, H-FL Series

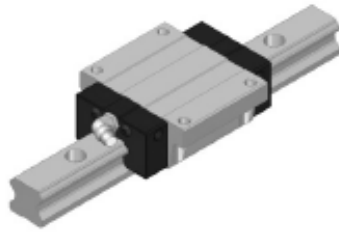

Model No.	External dimensions			Dimensions of LM block										H ₃
	Height H	Width W	Length L	B	C	M	L ₁	t	T	T ₁	N	E	Grease nipple	
H 15F	24	47	57	38	30	M5	40,8	—	7	11	6	6	A-M4	4,7
H 15FL	24	47	65,3	38	30	M5	49,1	—	7	11	6	6	A-M4	4,7
H 20F	30	63	72,7	53	40	M6	53,1	—	9,2	10	7,5	12	B-M6F	6
H 20FL	30	63	88,6	53	40	M6	69	—	9,2	10	7,5	12	B-M6F	6
H 25F	36	70	83	57	45	M8	58,3	—	11,5	16	9	12	B-M6F	7
H 25FL	36	70	102,9	57	45	M8	78,2	—	11,5	16	9	12	B-M6F	7
H 30F	42	90	97,8	72	52	M10	70,8	—	9,5	18	7,3	12	B-M6F	7,5
H 30FL	42	90	120	72	52	M10	93	—	9,5	18	7,3	12	B-M6F	7,5
H 35F	48	100	110	82	62	M10	80,8	—	12,5	21	8	12	B-M6F	9
H 35FL	48	100	135,4	82	62	M10	106,2	—	12,5	21	8	12	B-M6F	9
H 45F	60	120	139	100	80	M12	101,9	25	13	15	10	16	B-PT1/8	10
H 45FL	60	120	170,8	100	80	M12	133,7	25	13	15	10	16	B-PT1/8	10
H 55F	70	140	163	116	95	M14	117,5	29	19	17	11	16	B-PT1/8	13
H 55FL	70	140	201,1	116	95	M14	155,6	29	19	17	11	16	B-PT1/8	13

Composition of Model No.

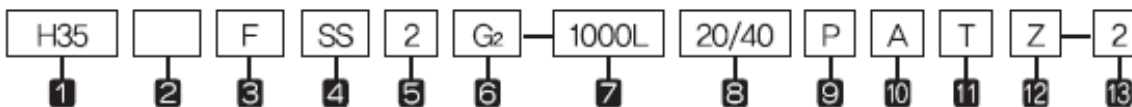

- 1 Model No. of Linear Motion Guide
 - 2 Type of block : No symbol—Full-ball type / S—Spacer retainer type
 - 3 Form of block : R—Rectangular standard type / RL—Rectangular long type / F—Flange standard type / FL—Flange long type
 - 4 Type of seal : UU—End seal / SS—End seal + Inside seal / ZZ—End seal + Inside seal + metal scraper (*1)
 - 5 Number of blocks combined in 1 rail
 - 6 Symbol of clearance : No symbol—Normal preload / G₁—Light preload / G₂—Heavy preload / G_s—Special preload (*2)
 - 7 Length of rail
 - 8 Size of G value : standard G value has no symbol.
 - 9 Symbol of precision : No symbol—Moderate precision / H—High precision / P—Precision / SP—Super Precision / UP—Ultra Precision (*3)
 - 10 No symbol—Rail counter bore type (A topside assembly) / A— Rail tap hole type (an underside assembly)
 - 11 Connection symbol
 - 12 Special symbol
 - 13 Number of axis used on the same surface
- (*1) See P85 Symbol List of Optional Parts (*2) See P17 Radial Clearance
(*3) See P24 Selection of Precision Class

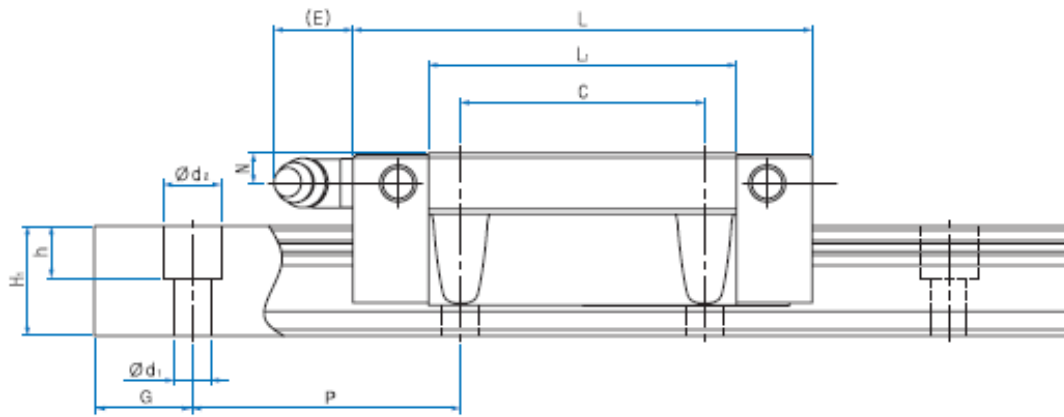

Unit : mm

Dimensions of LM Rail						Basic load rating		Static allowance moment kN·m					Mass	
Width W1 ±0.05	W2	Heigh H1	Value G	Pitch P	d1 x d2 x h	C kN	Co kN	Mp		My		Mr	LM Block kg	LM Rail kg/m
								1	2(contact)	1	2(contact)	1		
15	16	13	20	60	4,5X7,5X5,3	9,9	16,2	0,115	0,552	0,115	0,552	0,129	0,19	1,3
15	16	13	20	60	4,5X7,5X5,3	11,2	19,3	0,165	0,769	0,165	0,769	0,154	0,24	1,3
20	21,5	16,5	20	60	6X9,5X8,5	14,9	23,9	0,221	1,049	0,221	1,049	0,251	0,41	2,2
20	21,5	16,5	20	60	6X9,5X8,5	17,8	30,7	0,370	1,692	0,370	1,692	0,322	0,54	2,2
23	23,5	20	20	60	7X11X9	22,1	33,1	0,337	1,636	0,337	1,636	0,398	0,61	3,0
23	23,5	20	20	60	7X11X9	26,8	43,6	0,596	2,760	0,596	2,760	0,525	0,82	3,0
28	31	26	20	80	9X14X12	38,4	57,1	0,711	3,384	0,711	3,384	0,828	1,1	4,85
28	31	26	20	80	9X14X12	45,9	73,6	1,203	5,506	1,203	5,506	1,067	1,3	4,85
34	33	29	20	80	9X14X12	51,1	74,6	1,062	5,012	1,062	5,012	1,298	1,6	6,58
34	33	29	20	80	9X14X12	61,0	96,2	1,797	8,172	1,797	8,172	1,674	2,01	6,58
45	37,5	38	22,5	105	14X20X17	82,1	116,4	2,860	9,912	2,860	9,912	2,275	2,83	11,03
45	37,5	38	22,5	105	14X20X17	98,2	150,1	4,533	16,161	4,533	16,161	2,935	3,70	11,03
53	43,5	44	30	120	16X23X20	118,1	161,5	4,654	16,016	4,654	16,016	3,779	4,36	15,26
53	43,5	44	30	120	16X23X20	142,0	210,1	7,468	26,493	7,468	26,493	4,916	5,76	15,26

1N=0,102kgf

